

FRIDGE ALARM

The fridge alarm was designed to prevent the fridge door being left open but if the timing is turned down, can also be used to alert anyone that the fridge is being raided!

This circuit is activated when a light is shone upon the LDR which in this application would be the light from a fridge when the door is opened. This causes Q1 to conduct and activates the relay, The relay provides power to a standard 555 monostable that activates a buzzer when the output returns low after its timing period. The length of delay before the buzzer is activated can be adjusted by VR1.

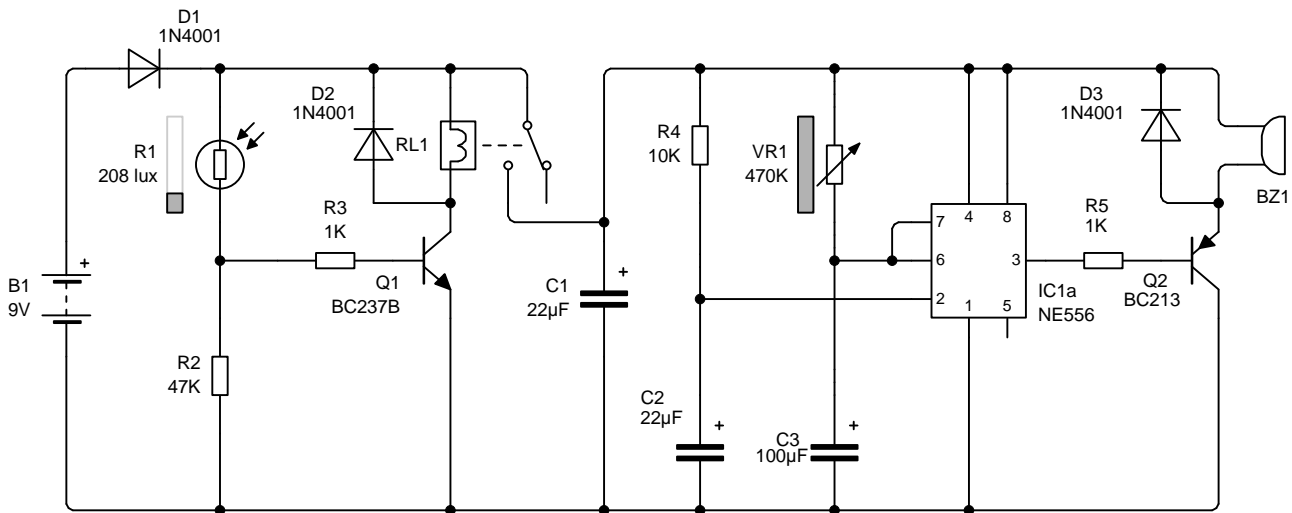

The standby current of this device is very low. In complete darkness, a typical LDR will have a resistance of around 1Mohm. This results in a standby current of around 1uA. A PP3 battery should last at least 6 months.

Design by Phil Tow nshend
w w w .edutek.ltd.uk

Name	Quantity
100µF Electrolytic Capacitor	1
10K Resistor (1/4W)	1
1K Resistor (1/4W)	2
1N4001 Diode	3
22µF Electrolytic Capacitor	2
470K Variable Resistor	1
47K Resistor (1/4W)	1
9V Battery (100mA)	1
BC213 PNP Transistor	1
BC237B NPN Transistor	1
Buzzer (6V)	1
LDR (ORP12)	1
NE555 Dual Bipolar Timer	1
SPDT Relay (6V)	1