

LITHIUM-ION/NIMH BATTERY CHARGER

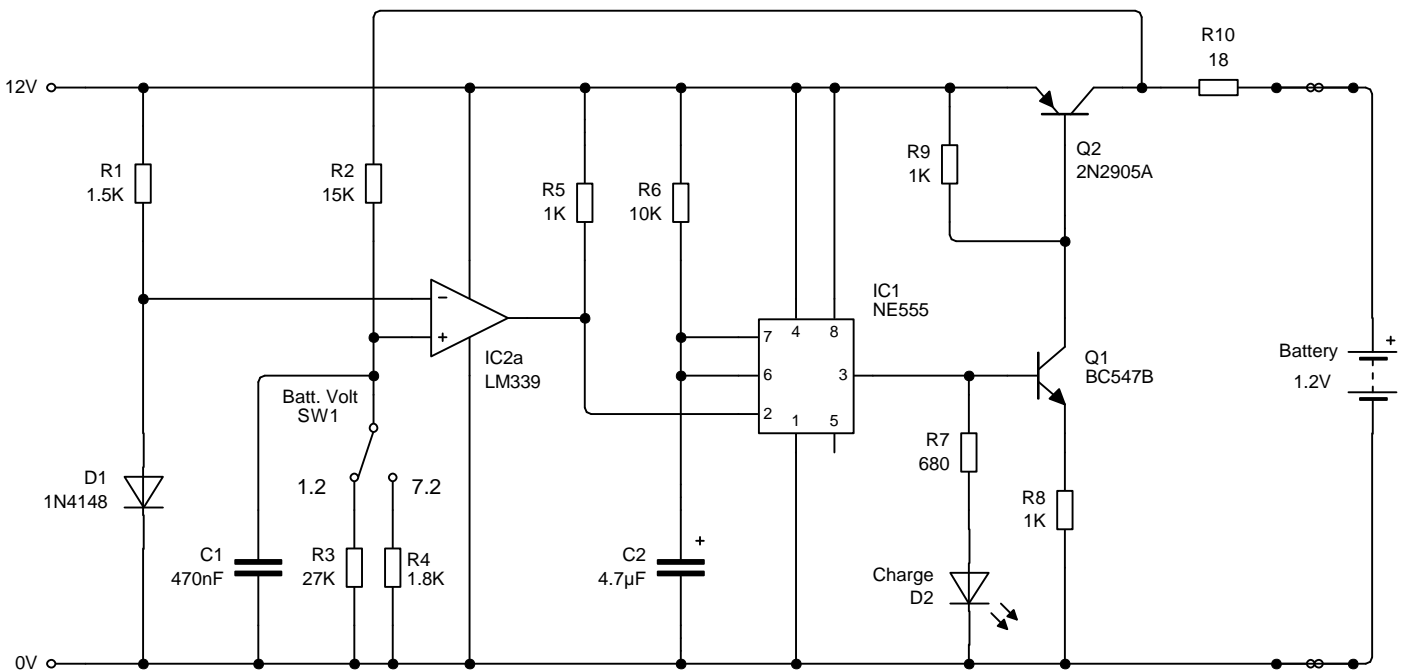

This is a clever little circuit that I found on Bill Bowden's Hobby Circuits site. It generates pulses of charge and measures the battery voltage inbetween ceasing when the battery is full.

I've made a few alterations but essentially it works the same way. A comparator compares the battery voltage against a potential divider based upon R1/D1 which is fixed at 0.7 volts. It is kept this low to enable 1.2 volt NIMH batteries to be used. Different battery voltages can be charged by altering the potential divider R2/R3 or R4. The supply should be at least 3v higher than the battery you need to charge.

If the battery voltage drops below the preset level, the comparators output goes low and triggers the 555 monostable. This produces a short pulse of

$$1.1 \times C2 \times R6 = 1.1 \times 0.00001 \times 10,000 = 110\text{ms}$$

Sufficient current to charge the battery is generated by Q1 and Q2. After the pulse has charged the battery, the voltage is compared again and another pulse is triggered if the battery voltage has not met the preset level. This repeats at a rate reliant upon the charge hold capability (or strength) of the battery.

A good tip was to use a capacitor of about 1000uF for more instead of a battery for testing purposes.

Name	Quantity
1.1V Battery (Ideal)	1
1.5K Resistor (1/4W)	1
1.8K Resistor (1/4W)	1
10K Resistor (1/4W)	1
12V Voltage Rail (Ideal)	1
15K Resistor (1/4W)	1
18 Resistor (1/4W)	1
1K Resistor (1/4W)	3
1N4148 Diode	1
27K Resistor (1/4W)	1
2N2905A PNP Transistor	1
4.7µF Electrolytic Capacitor	1
470nF Capacitor	1
680 Resistor (1/4W)	1
BC547B NPN Transistor	1
LED (Red)	1
LM339 Operational Amplifier	1
NE555 Bipolar Timer	1
SPDT Switch	1