

PULSED TONE GENERATOR - Bite Alarm

This circuit is based around two astables and produces a pulsed tone whose speed, pitch, duration and volume can all be adjusted. The PCB has off board connections for the pitch and volume with the speed and duration adjustments via presets.

This was originally designed for a fishing bite alarm but has many applications elsewhere. A small 38mm ultra-thin speaker was used and gives a surprisingly good output. But the bigger the speaker the louder and better the tone.

If used for long durations with an 8 ohm speaker you may need to mount a clip-on heatsink to T2 as it will get hot.

Use CMOS versions of the 555 timer (7555) if possible to prolong battery life. A PP3 9v battery is ideal.

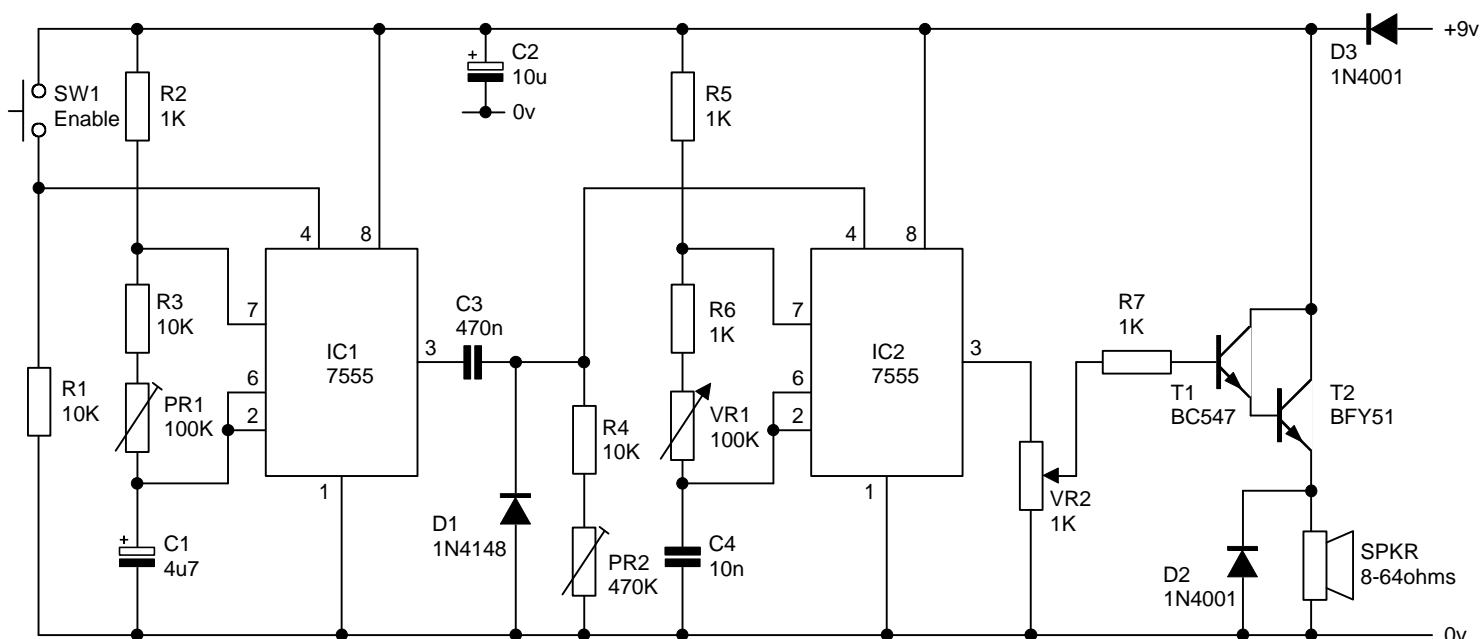

Board size: 68mm x 41mm

