

LOW POWER DUAL VOLTAGE COMPARATORS

- WIDE SINGLE SUPPLY VOLTAGE RANGE OR DUAL SUPPLIES +2V TO +36V OR $\pm 1V$ TO $\pm 18V$
- VERY LOW SUPPLY CURRENT (0.4mA) INDEPENDENT OF SUPPLY VOLTAGE (1 mW/comparator at +5V)
- LOW INPUT BIAS CURRENT : 25nA TYP
- LOW INPUT OFFSET CURRENT : $\pm 5nA$ TYP
- LOW INPUT OFFSET VOLTAGE : $\pm 1mV$ TYP
- INPUT COMMON-MODE VOLTAGE RANGE INCLUDES GROUND
- LOW OUTPUT SATURATION VOLTAGE : 250mV TYP. ($I_o = 4mA$)
- DIFFERENTIAL INPUT VOLTAGE RANGE EQUAL TO THE SUPPLY VOLTAGE
- TTL, DTL, ECL, MOS, CMOS COMPATIBLE OUTPUTS

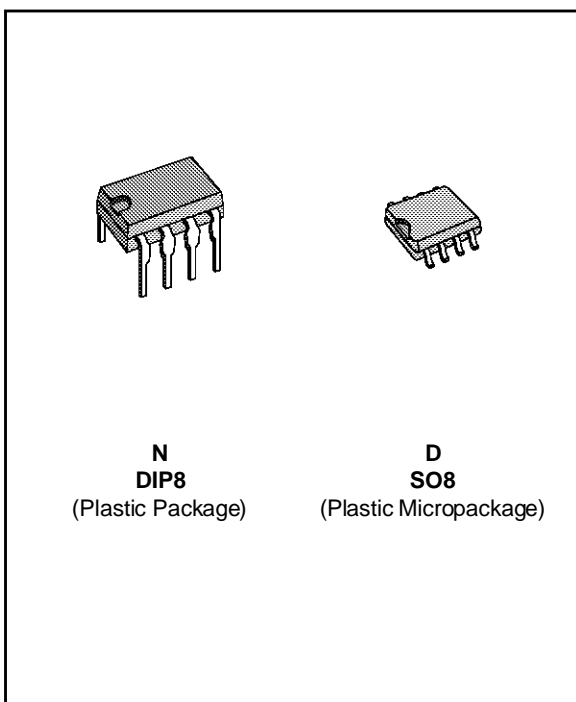

DESCRIPTION

These devices consist of two independent low power voltage comparators designed specifically to operate from a single supply over a wide range of voltages. Operation from split power supplies is also possible.

These comparators also have a unique characteristic in that the input common-mode voltage range includes ground even though operated from a single power supply voltage.

ORDER CODES

| Part Number | Temperature Range | Package | |
|-------------------------|-------------------|---------|---|
| | | N | D |
| LM193 | -55, +125°C | • | • |
| LM293 | -40, +105°C | • | • |
| LM393 | 0, +70°C | • | • |
| Example : LM393D | | | |

PIN CONNECTIONS (top views)

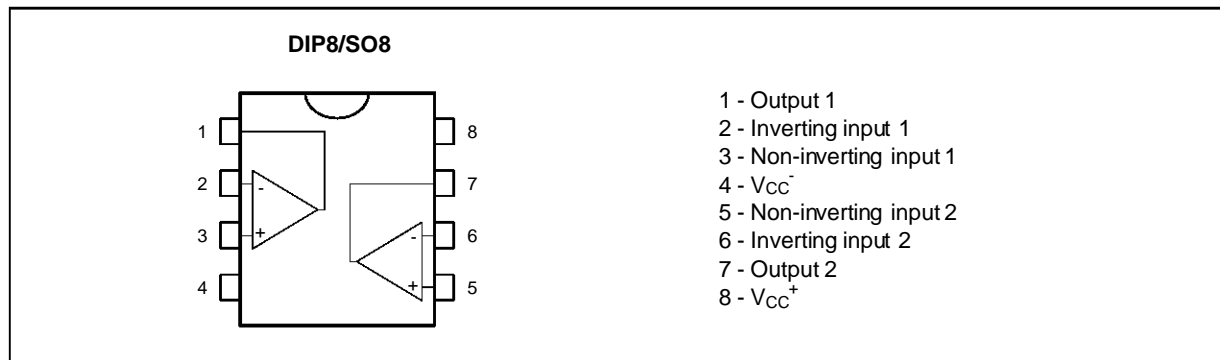

SCHEMATIC DIAGRAM (1/2 LM193)

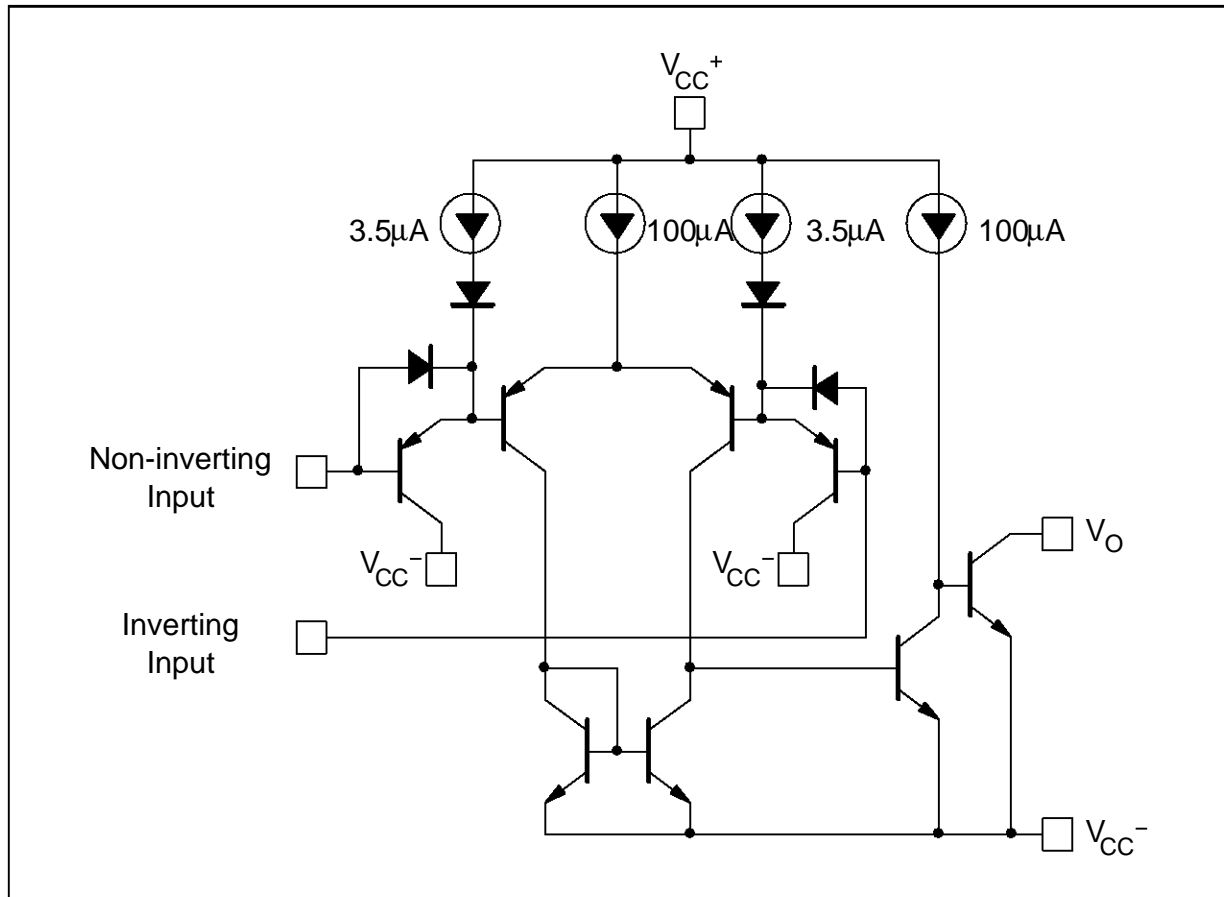

193-02.EPS

ABSOLUTE MAXIMUM RATINGS

| Symbol | Parameter | LM193 | LM293 | LM393 | Unit |
|------------|---|----------------|----------------|----------------|-------------|
| V_{CC} | Supply Voltage | ± 18 or 36 | ± 18 or 36 | ± 18 or 36 | V |
| V_{id} | Differential Input Voltage | ± 36 | ± 36 | ± 36 | V |
| V_i | Input Voltage | -0.3 to +36 | -0.3 to +36 | -0.3 to +36 | V |
| | Output Short-circuit to Ground – (note 1) | Infinite | | | |
| P_{tot} | Power Dissipation | 830 | | | mW |
| T_{oper} | Operating Free-air Temperature Range | -55 to +125 | -40 to +105 | 0 to +70 | $^{\circ}C$ |
| T_{stg} | Storage Temperature Range | -65 to +150 | -65 to +150 | -65 to +150 | $^{\circ}C$ |

193-02.TBL

Notes : 1. Short-circuit from the output to V_{CC}^+ can cause excessive heating and eventual destruction. The maximum output current is approximately 20mA, independent of the magnitude of V_{CC}^+ .

ELECTRICAL CHARACTERISTICS

$V_{CC}^+ = +5V$, $V_{CC}^- = 0V$, $T_{amb} = 25^{\circ}C$ (unless otherwise specified)

| Symbol | Parameter | LM193 - LM293 - LM393 | | | Unit |
|------------|---|-----------------------|----------|------------------------------------|---------------|
| | | Min. | Typ. | Max. | |
| V_{io} | Input Offset Voltage – (note 2) $T_{amb} = +25^{\circ}C$ $T_{min.} \leq T_{amb} \leq T_{max.}$ | | 1 | 5 9 | mV |
| I_{ib} | Input Bias Current – (note 3) $T_{amb} = +25^{\circ}C$ $T_{min.} \leq T_{amb} \leq T_{max.}$ | | 25 | 250 400 | nA |
| I_{io} | Input Offset Current $T_{amb} = +25^{\circ}C$ $T_{min.} \leq T_{amb} \leq T_{max.}$ | | 5 | 50 150 | nA |
| A_{vd} | Large Signal Voltage Gain $V_{CC} = 15V$, $R_L = 15k\Omega$, $V_o = 1$ to $11V$ | 50 | 200 | | V/mV |
| I_{CC} | Supply Current (all comparators) $V_{CC} = 5V$, no load $V_{CC} = 30V$, no load | | 0.4 1 | 1 2.5 | mA |
| V_{icm} | Input Common Mode Voltage Range - (note 4) $T_{amb} = +25^{\circ}C$ $T_{min.} \leq T_{amb} \leq T_{max.}$ | 0 0 | | $V_{CC}^+ - 1.5$ $V_{CC}^+ - 2$ | V |
| V_{id} | Differential Input Voltage - (note 6) | | | V_{CC}^+ | V |
| I_{sink} | Output Sink Current ($V_{id} = -1V$, $V_o = 1.5V$) | 6 | 16 | | mA |
| V_{OL} | Low Level Output Voltage ($V_{id} = -1V$, $I_{sink} = 4mA$) $T_{amb} = 25^{\circ}C$ $T_{min.} \leq T_{amb} \leq T_{max.}$ | | 250 | 400 700 | mV |
| I_{OH} | High Level Output Current ($V_{id} = 1V$, $V_{CC} = V_o = 30V$) $T_{amb} = 25^{\circ}C$ $T_{min.} \leq T_{amb} \leq T_{max.}$ | | 0.1 | 1 | nA μA |
| t_{re} | Response Time ($R_L = 5.1k\Omega$ to V_{CC}^+) – (note 5) | | 1.3 | | μs |
| t_{rel} | Large Signal Response Time ($V_i = TTL$, $V_{ref} = +1.4V$, $R_L = 5.1k\Omega$ to V_{CC}^+) | | 300 | | ns |

193-03.TBL

- Notes :**
- At output switch point, $V_o \approx 1.4V$, $R_s = 0\Omega$ with V_{CC}^+ from 5V to 30V and over the full input common-mode range (0V to $V_{CC}^+ - 1.5V$).
 - The direction of the input current is out of the IC due to the PNP input stage. This current is essentially constant, independent of the state of the output, so no loading charge exists on the reference or input lines.
 - The input common-mode voltage of either input signal voltage should not be allowed to go negative by more than 0.3V.
The upper end of the common-mode voltage range is $V_{CC}^+ - 1.5V$, but either or both inputs can go to +30V without damage.
 - The response time specified is for a 100mV input step with 5mV overdrive. For larger overdrive signals 300ns can be obtained.
 - Positive excursions of input voltage may exceed the power supply level. As long as the other voltage remains within the common-mode range the comparator will provide a proper output state. The low input voltage state must not be less than -0.3V (or 0.3V below the negative power supply, if used).

SUPPLY CURRENT versus SUPPLY VOLTAGE

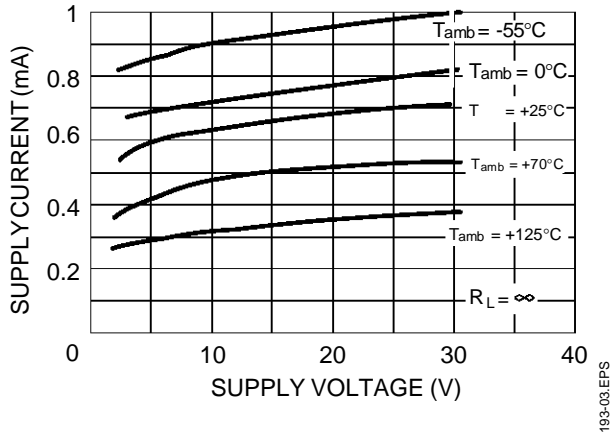

INPUT CURRENT versus SUPPLY VOLTAGE

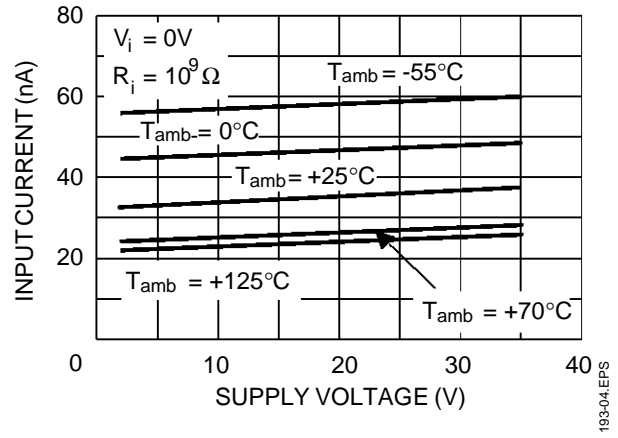

OUTPUT SATURATION VOLTAGE versus OUTPUT CURRENT

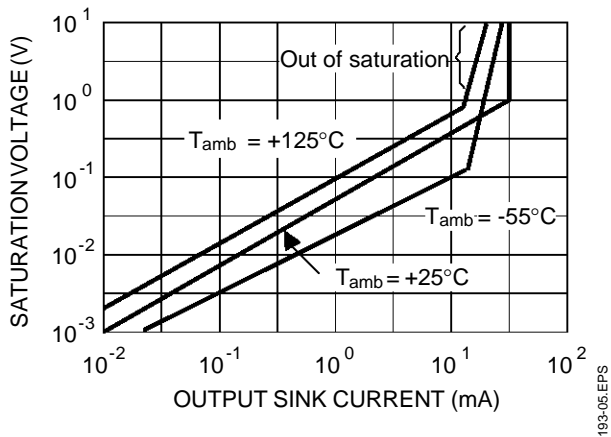

RESPONSE TIME FOR VARIOUS INPUT OVERDRIVES - NEGATIVE TRANSITION

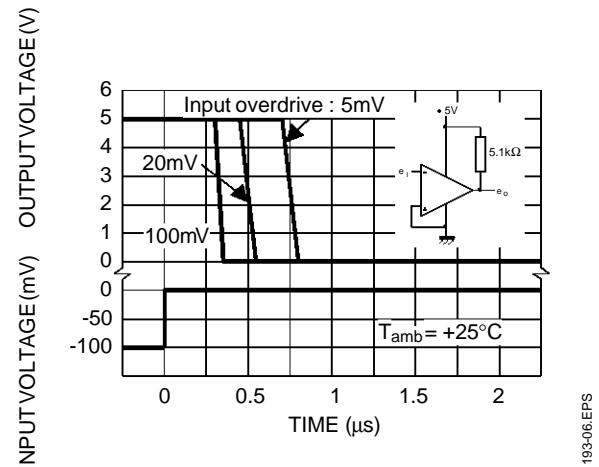

RESPONSE TIME FOR VARIOUS INPUT OVERDRIVES - POSITIVE TRANSITION

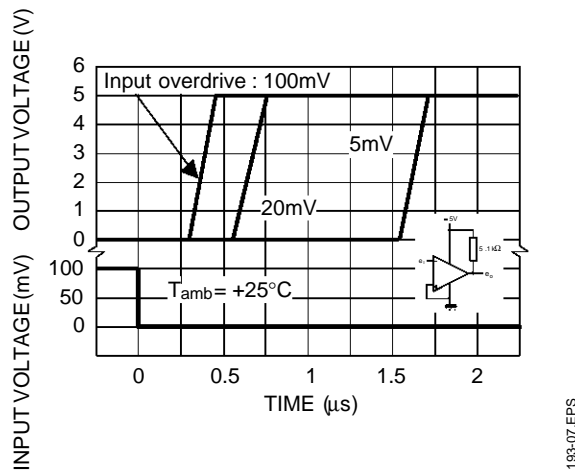

TYPICAL APPLICATIONS

BASIC COMPARATOR

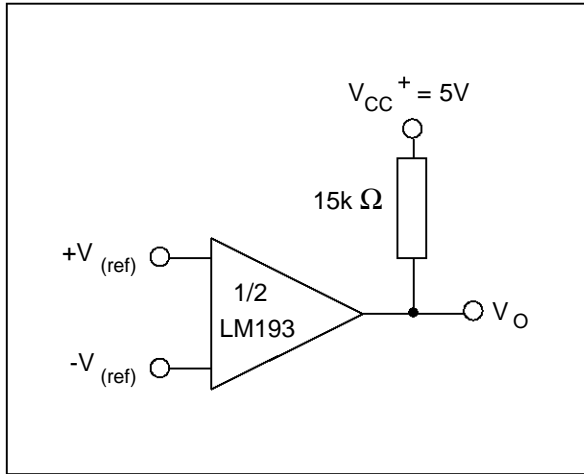

DRIVING CMOS

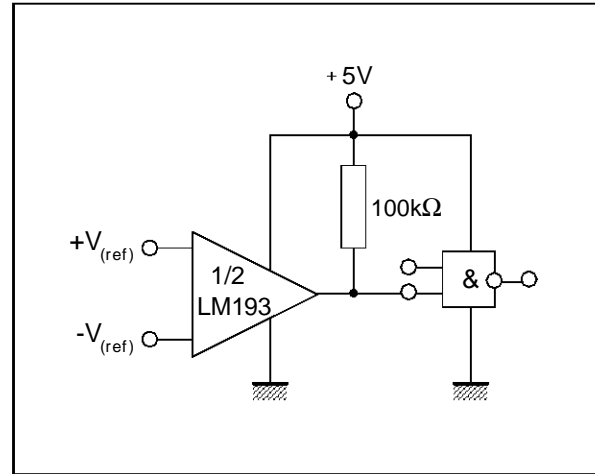

DRIVING TTL

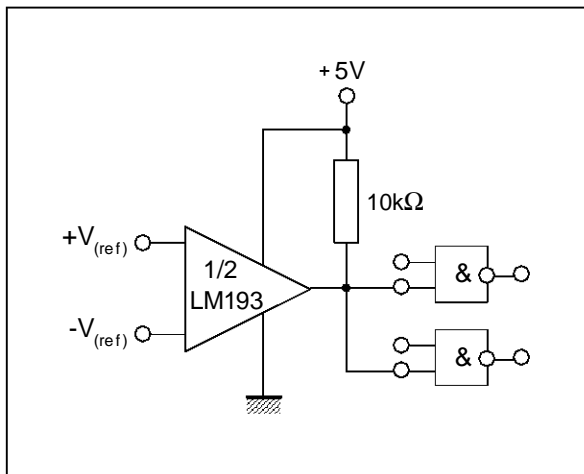

LOW FREQUENCY OP AMP

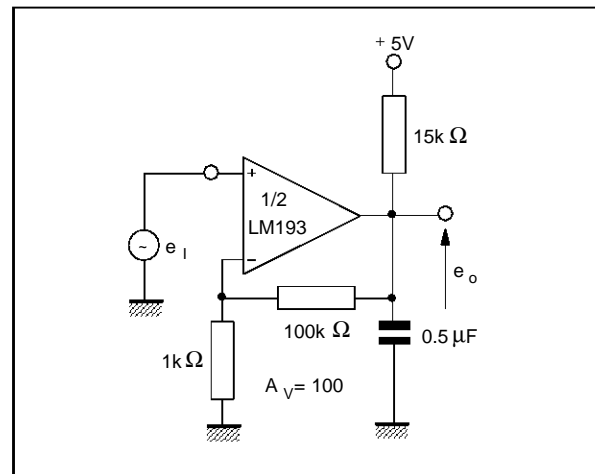

LOW FREQUENCY OP AMP

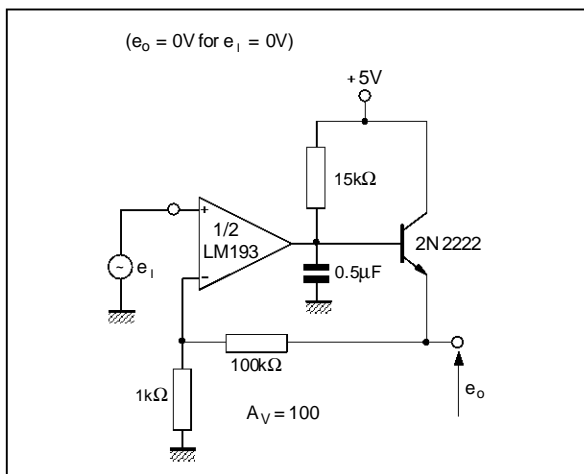

TRANSDUCER AMPLIFIER

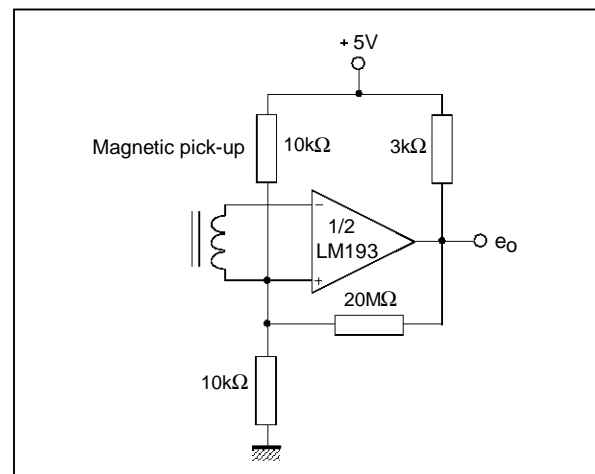

LM193 - LM293 - LM393

LOW FREQUENCY OP AMP WITH OFFSET ADJUST

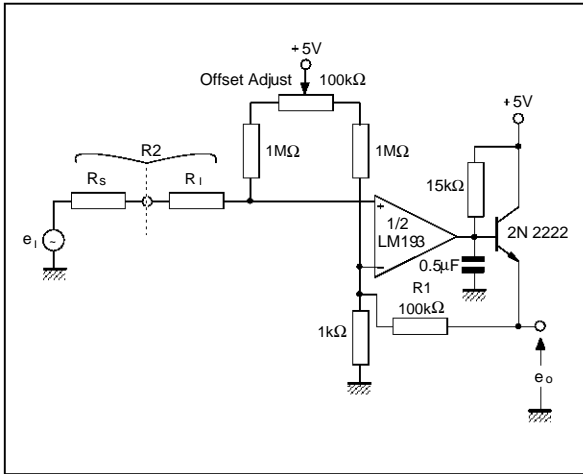

ZERO CROSSING DETECTOR (SINGLE POWER SUPPLY)

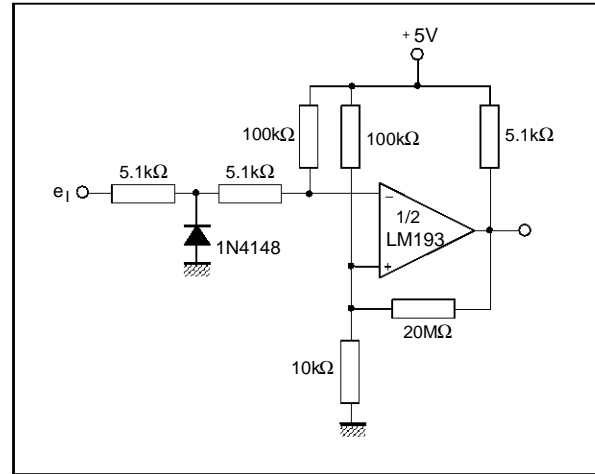

TWO DECADES HIGH FREQUENCY VCO

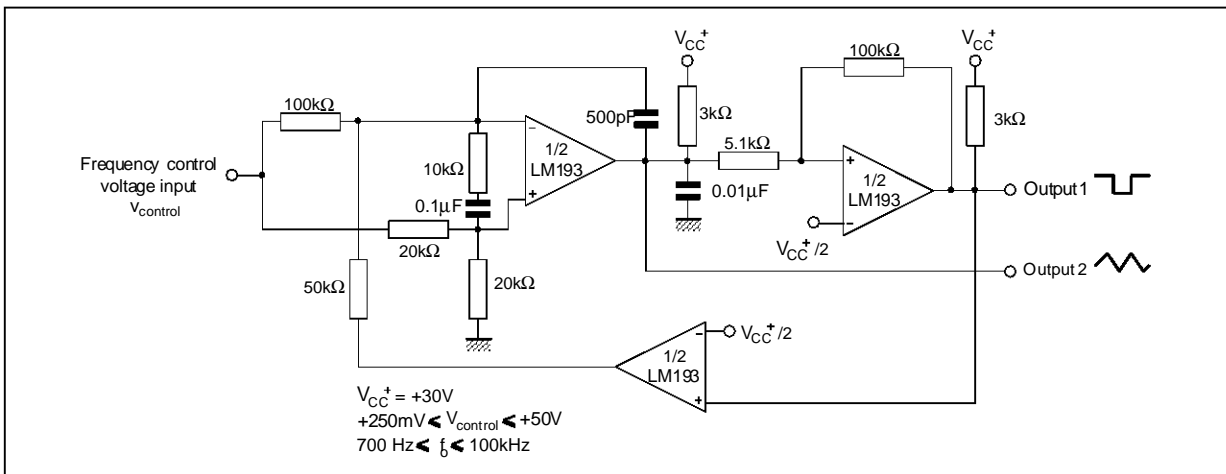

LIMIT COMPARATOR

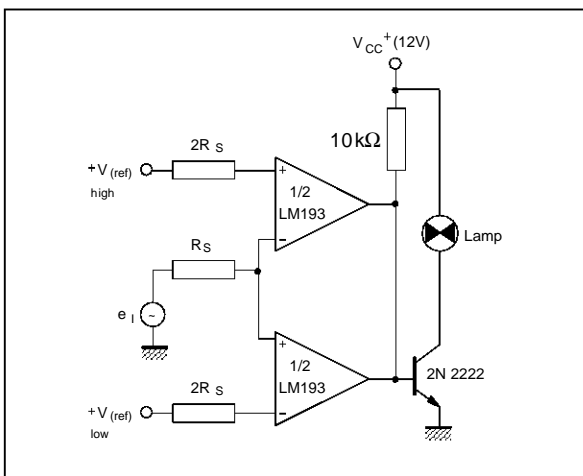

CRYSTAL CONTROLLED OSCILLATOR

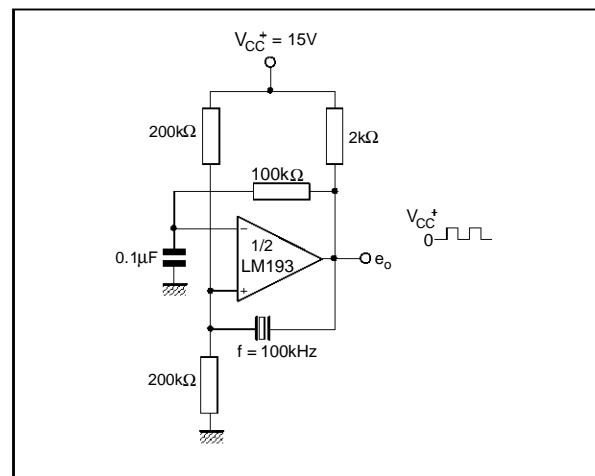

SPLIT-SUPPLY APPLICATIONS
ZERO CROSSING DETECTOR

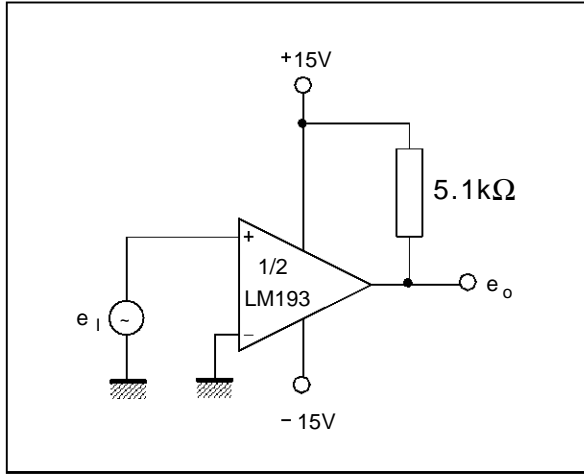

COMPARATOR WITH A NEGATIVE REFERENCE

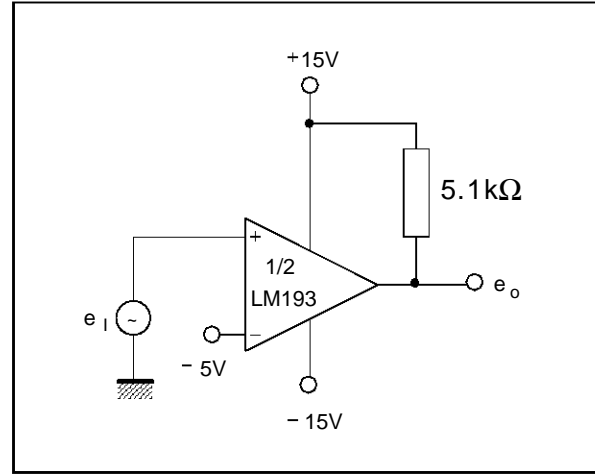

LM193 - LM293 - LM393

PACKAGE MECHANICAL DATA 8 PINS -PLASTIC DIP OR CERDIP

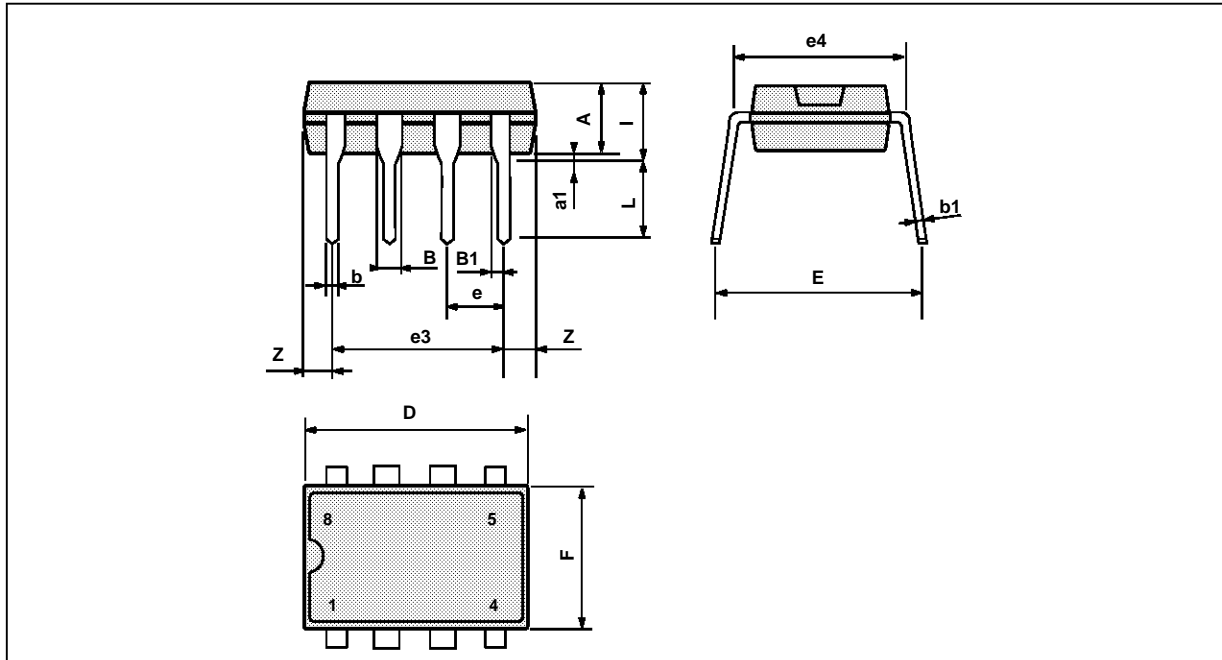

PM-DIP8.EFS

| Dimensions | Millimeters | | | Inches | | |
|------------|-------------|------|-------|--------|-------|-------|
| | Min. | Typ. | Max. | Min. | Typ. | Max. |
| A | | 3.32 | | | 0.131 | |
| a1 | 0.51 | | | 0.020 | | |
| B | 1.15 | | 1.65 | 0.045 | | 0.065 |
| b | 0.356 | | 0.55 | 0.014 | | 0.022 |
| b1 | 0.204 | | 0.304 | 0.008 | | 0.012 |
| D | | | 10.92 | | | 0.430 |
| E | 7.95 | | 9.75 | 0.313 | | 0.384 |
| e | | 2.54 | | | 0.100 | |
| e3 | | 7.62 | | | 0.300 | |
| e4 | | 7.62 | | | 0.300 | |
| F | | | 6.6 | | | 0.260 |
| i | | | 5.08 | | | 0.200 |
| L | 3.18 | | 3.81 | 0.125 | | 0.150 |
| Z | | | 1.52 | | | 0.060 |

DIP8.TBL

PACKAGE MECHANICAL DATA
8 PINS -PLASTIC MICROPACKAGE (SO)

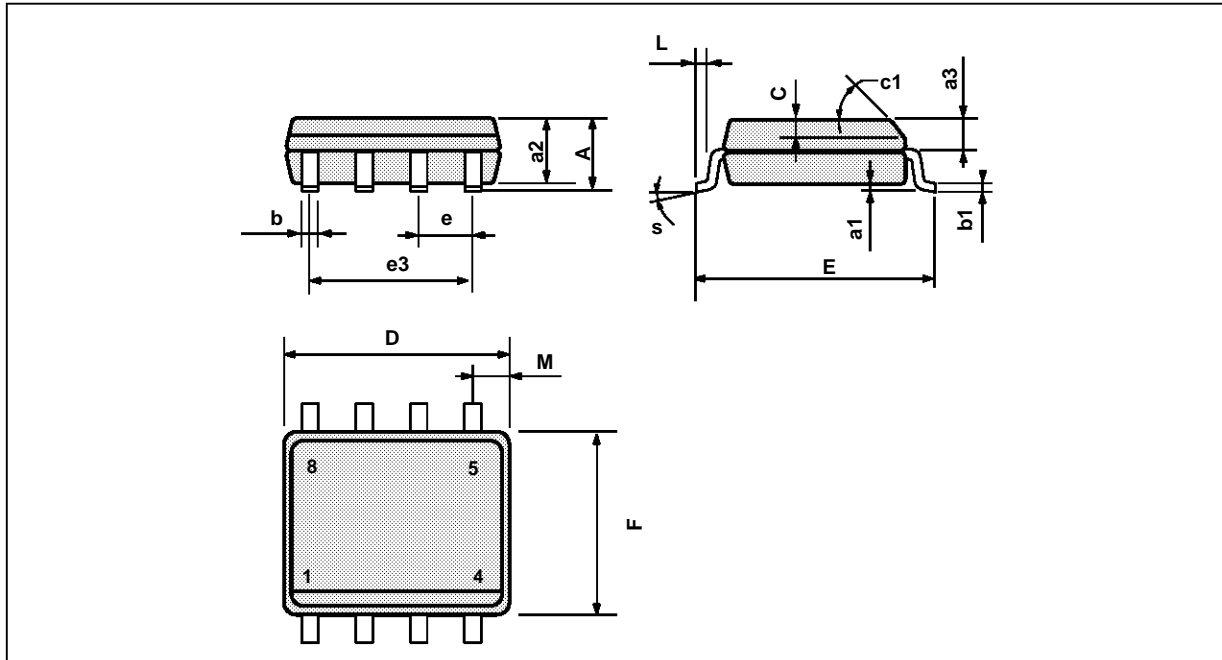

PM-S08-EPS

| Dimensions | Millimeters | | | Inches | | |
|------------|-------------|------|------|--------|-------|-------|
| | Min. | Typ. | Max. | Min. | Typ. | Max. |
| A | | | 1.75 | | | 0.069 |
| a1 | 0.1 | | 0.25 | 0.004 | | 0.010 |
| a2 | | | 1.65 | | | 0.065 |
| a3 | 0.65 | | 0.85 | 0.026 | | 0.033 |
| b | 0.35 | | 0.48 | 0.014 | | 0.019 |
| b1 | 0.19 | | 0.25 | 0.007 | | 0.010 |
| C | 0.25 | | 0.5 | 0.010 | | 0.020 |
| c1 | 45° (typ.) | | | | | |
| D | 4.8 | | 5.0 | 0.189 | | 0.197 |
| E | 5.8 | | 6.2 | 0.228 | | 0.244 |
| e | | 1.27 | | | 0.050 | |
| e3 | | 3.81 | | | 0.150 | |
| F | 3.8 | | 4.0 | 0.150 | | 0.157 |
| L | 0.4 | | 1.27 | 0.016 | | 0.050 |
| M | | | 0.6 | | | 0.024 |
| S | 8° (max.) | | | | | |

S08.TBL

Information furnished is believed to be accurate and reliable. However, SGS-THOMSON Microelectronics assumes no responsibility for the consequences of use of such information nor for any infringement of patents or other rights of third parties which may result from its use. No licence is granted by implication or otherwise under any patent or patent rights of SGS-THOMSON Microelectronics. Specifications mentioned in this publication are subject to change without notice. This publication supersedes and replaces all information previously supplied. SGS-THOMSON Microelectronics products are not authorized for use as critical components in life support devices or systems without express written approval of SGS-THOMSON Microelectronics.

© 1994 SGS-THOMSON Microelectronics - All Rights Reserved

SGS-THOMSON Microelectronics GROUP OF COMPANIES

Australia - Brazil - France - Germany - Hong Kong - Italy - Japan - Korea - Malaysia - Malta - Morocco - The Netherlands
Singapore - Spain - Sweden - Switzerland - Taiwan - Thailand - United Kingdom - U.S.A.

ORDER CODE