

# PCB ROUTING

Below is a circuit diagram of a CMOS logic gate astable. To the right is the pin connections for a 4011 IC, which has 4 NAND gates. Using the PCB below, show where you would draw copper tracks to connect up the components to the logic gates and then to the output connection. Remember you can route tracks under components as well as around them.

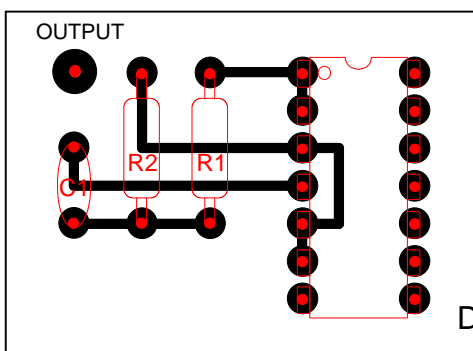
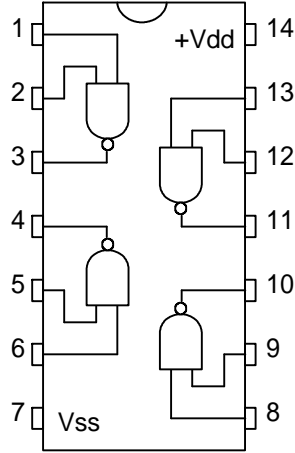
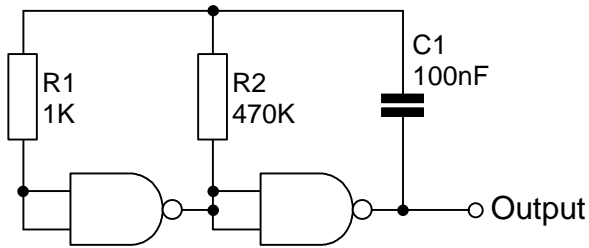

Draw your solution on this PCB

Below is another astable based upon a 555 timer IC. Connect up the 6 components and the power supply to form a working PCB of the astable.

