

DOUBLE DIGITAL DICE

This double dice circuit features a power down function to save on battery consumption. Press the "roll" button to roll the dice, the LED's stay on for approximately 10 seconds then go out.

To alter this time, change R2 or C1.

The LED's are soldered directly to the board and form the classic dice dot layout. Each dice has its own astable set at around 150Hz. Use 5mm LED's for best effect.

Circuit Diagram

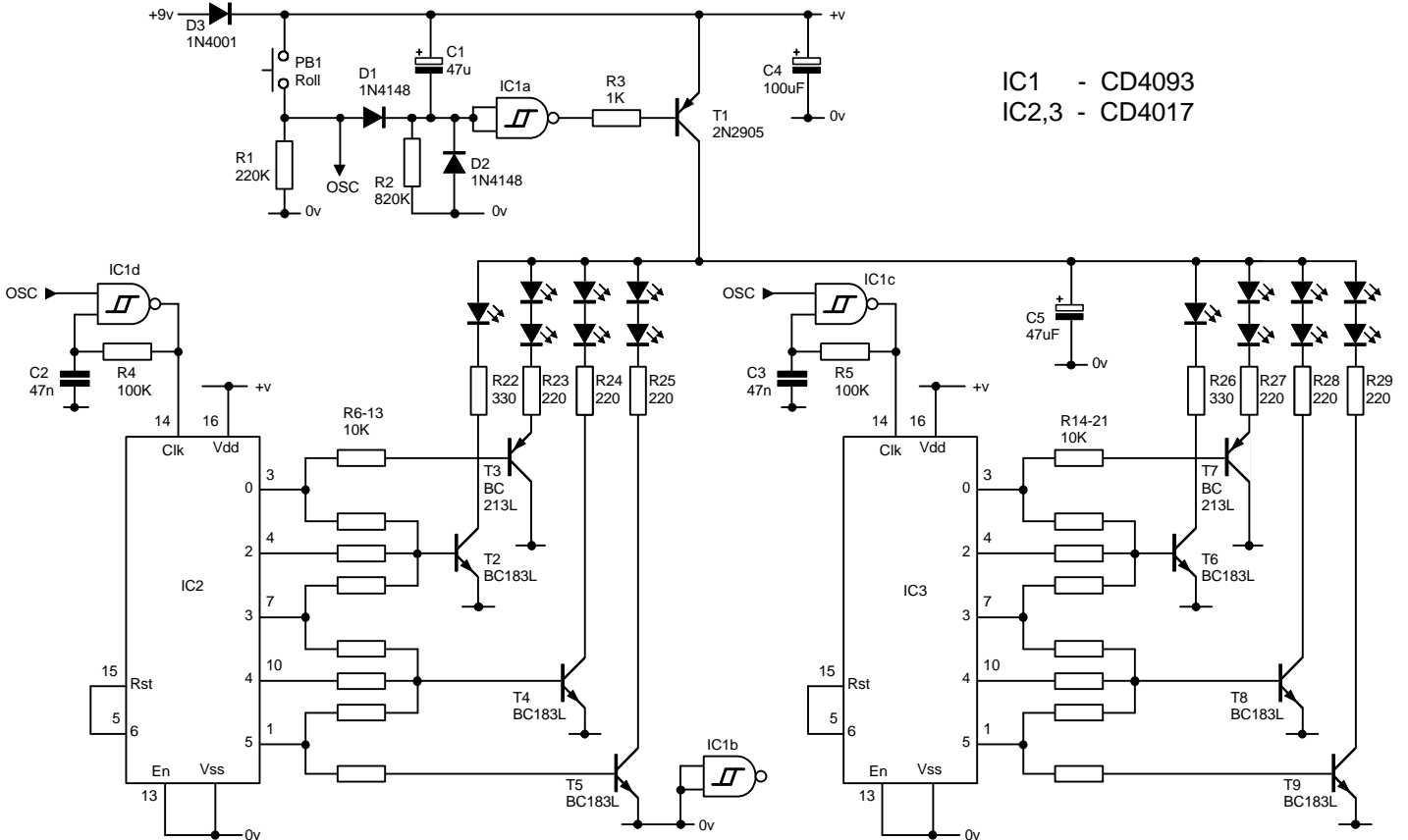

Board size: 86mm x 74mm

