

LOTTERY RANDOM NUMBER GENERATOR - Designed by Phil Townshend

This circuit will count from 1 to 49 and then repeat. Press "Run" to generate the number.

Circuit Diagram

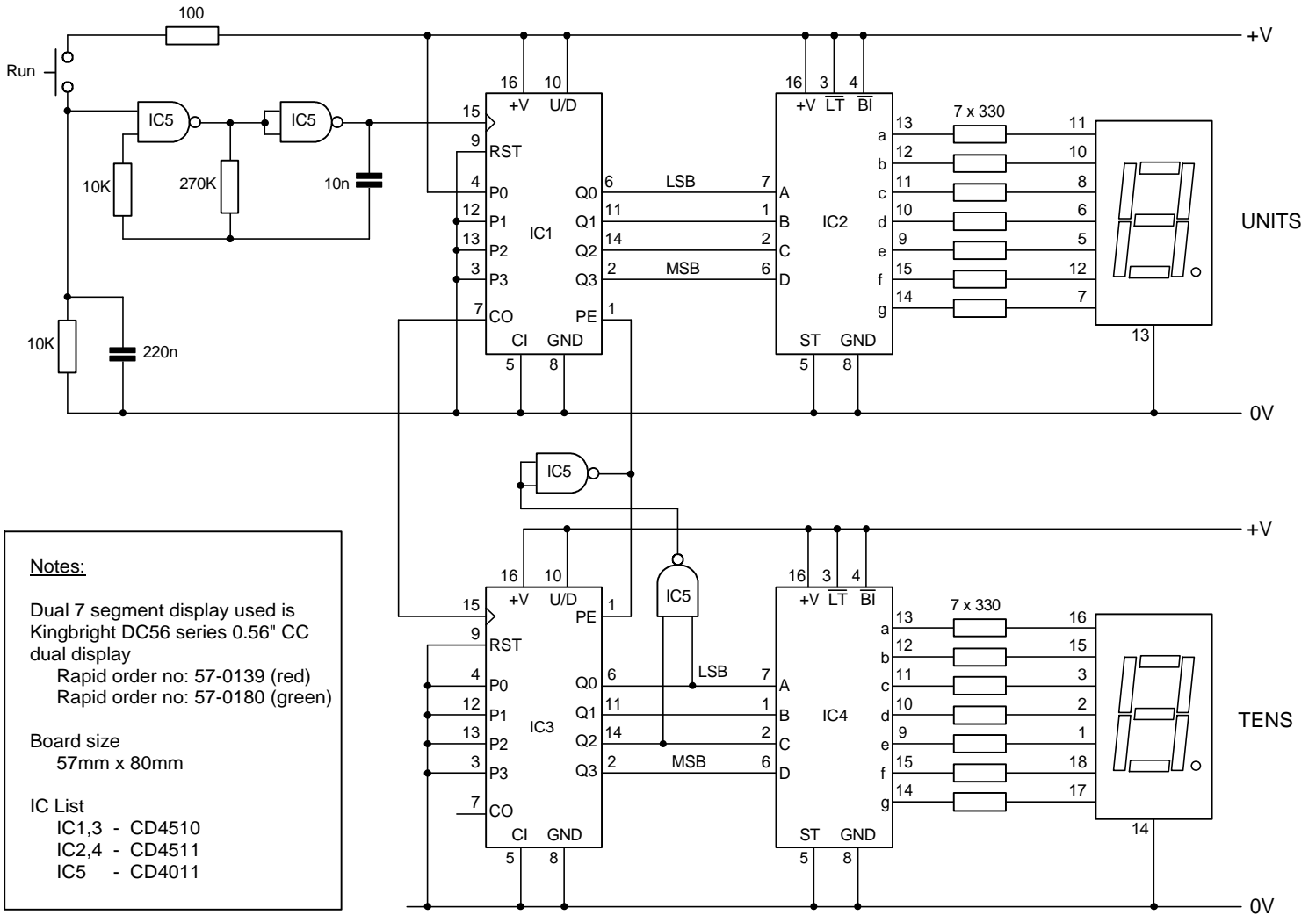

Notes:

Dual 7 segment display used is Kingbright DC56 series 0.56" CC dual display
 Rapid order no: 57-0139 (red)
 Rapid order no: 57-0180 (green)

Board size
 57mm x 80mm

IC List
 IC1,3 - CD4510
 IC2,4 - CD4511
 IC5 - CD4011

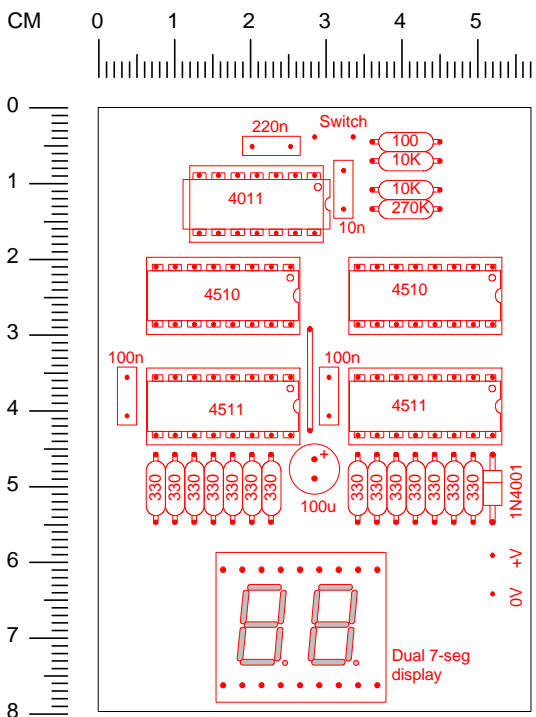

UNDERSIDE VIEW

